

# Installation instructions (original)

Transportation | Assembly | Operation | Maintenance



Product line:	Drainable Dry coolers
Series description:	Axial dry coolers, horizontal
Series:	GFH E

[www.guentner.de](http://www.guentner.de)

# Contents

<b>1</b>	<b>Important basic information.....</b>	<b>5</b>
1.1	<b>Safety instructions.....</b>	<b>5</b>
1.1.1	Observing operating instructions.....	5
1.2	<b>Importance of the EN 378 series of standards – refrigeration systems and heat pumps – safety-related and environmental requirements.....</b>	<b>5</b>
1.3	<b>Responsibilities.....</b>	<b>5</b>
1.3.1	Manufacturer's responsibilities.....	5
1.3.2	Responsibilities of the system's installer.....	6
1.3.3	Owner or operator responsibilities.....	6
1.4	<b>Legal notes.....</b>	<b>7</b>
1.5	<b>Operating instructions.....</b>	<b>7</b>
1.5.1	Scope.....	7
1.5.2	Set-up and other applicable documents.....	7
1.6	<b>Conventions.....</b>	<b>8</b>
1.6.1	Typographical conventions.....	8
1.6.2	List of abbreviations.....	8
1.7	<b>Conventions for safety signs and notices.....</b>	<b>9</b>
1.7.1	General safety signs and their meaning in these operating instructions.....	9
1.7.2	Warning symbols and their meaning in these operating instructions.....	9
1.7.3	Prohibitory signs and their meaning in these operating instructions.....	10
1.7.4	Mandatory signs and their meaning in these operating instructions.....	10
<b>2</b>	<b>Safety.....</b>	<b>12</b>
2.1	<b>Labelling on the unit:.....</b>	<b>12</b>
2.1.1	Safety signs on the unit.....	12
2.1.2	Other signs and notes on the unit.....	14
2.2	<b>Basic safety notices.....</b>	<b>15</b>
2.2.1	How to act in an emergency.....	15
2.2.2	Personnel, care requirements.....	16
2.3	<b>Proper intended use.....</b>	<b>16</b>
2.3.1	Proper intended use.....	16
2.3.2	Operating conditions.....	16
2.3.3	Improper use.....	17
2.4	<b>Mechanical residual hazards.....</b>	<b>18</b>
2.4.1	Fins, sharp unit corners and edges.....	18
2.4.2	Fans.....	19
2.5	<b>Electrical residual hazards.....</b>	<b>19</b>

2.6	<b>Thermal residual hazards.....</b>	<b>20</b>
2.6.1	Danger of burns.....	20
2.6.2	Frostbite hazard.....	20
2.7	<b>Residual hazards due to the heat carrier glycol.....</b>	<b>20</b>
2.8	<b>Residual hazards caused by vibrations.....</b>	<b>22</b>
2.9	<b>Residual hazards caused by pressurised parts.....</b>	<b>22</b>
2.10	<b>Residual hazards caused by defective installation.....</b>	<b>23</b>
2.11	<b>Residual hazards with break during operation.....</b>	<b>24</b>
2.12	<b>Residual hazards caused by escaping objects or liquids.....</b>	<b>25</b>
2.13	<b>Residual hazards with disposal.....</b>	<b>25</b>
<b>3</b>	<b>Technical data.....</b>	<b>26</b>
3.1	Heat exchanger (typical values).....	26
3.2	Fans.....	26
<b>4</b>	<b>Set-up and function.....</b>	<b>28</b>
<b>5</b>	<b>Fan motor.....</b>	<b>29</b>
<b>6</b>	<b>Transportation and storage.....</b>	<b>30</b>
6.1	Safety.....	30
6.2	Transportation and storage.....	30
6.3	Storage before installation.....	32
<b>7</b>	<b>Set-up and start-up.....</b>	<b>33</b>
7.1	<b>Safety.....</b>	<b>33</b>
7.1.1	Safety instructions for set-up and start-up.....	33
7.1.2	System-side safety requirements.....	34
7.1.3	Customer-side safety precautions.....	35
7.2	<b>Requirements at the set-up point.....</b>	<b>36</b>
7.3	<b>Unpacking the unit.....</b>	<b>36</b>
7.4	<b>Installation.....</b>	<b>37</b>
7.4.1	System-side requirements for stress-free installation.....	37
7.4.2	Mounting the unit.....	38
7.5	<b>Notes on connecting the unit.....</b>	<b>38</b>
7.5.1	Connect the unit to the system.....	38
7.5.2	Unit electrical connection and protection.....	40
7.6	<b>Perform acceptance test.....</b>	<b>41</b>
7.7	<b>Test readiness for operation.....</b>	<b>42</b>
7.8	<b>Putting the unit into operation for the first time.....</b>	<b>42</b>
<b>8</b>	<b>Operation.....</b>	<b>44</b>
8.1	Safety.....	44
8.2	Putting the unit into operation.....	44
8.3	Taking the unit out of operation.....	44
8.4	Shutting the unit down.....	45

8.5	Putting the unit into operation after a shutdown.....	46
8.6	Changing the unit over to another working fluid.....	46
<b>9</b>	<b>Troubleshooting.....</b>	<b>47</b>
9.1	Safety.....	47
9.2	Service.....	47
9.3	Troubleshooting table.....	47
<b>10</b>	<b>Maintenance.....</b>	<b>48</b>
10.1	Safety.....	48
10.1.1	Before starting all maintenance.....	48
10.1.2	With all maintenance work.....	48
10.1.3	After all maintenance work.....	49
10.2	Inspection and maintenance plan.....	49
10.2.1	Fans.....	49
10.2.2	Unit heat exchanger.....	50
10.3	Maintenance work.....	51
10.3.1	Remove leaks.....	51
10.4	Clean unit.....	51
10.4.1	General.....	51
10.4.2	Clean and defrost heat exchanger.....	51
10.4.3	Cleaning fans.....	53
<b>11</b>	<b>Plans/diagrams.....</b>	<b>55</b>
11.1	Electrics documentation.....	55
11.1.1	Fan motor connection diagram.....	55
11.1.2	Connection diagram electrical defrost (selectable option; accessory on customer request).....	55

# 1 Important basic information

## 1.1 Safety instructions

### 1.1.1 Observing operating instructions

#### CAUTION

- ▶ Always keep the operating instructions in the unit's immediate vicinity at all times.
- ▶ Ensure that the operating instructions are accessible to all people that have anything at all to do with the unit at all times.
- ▶ Ensure that the operating instructions are read and understood by all people that have anything at all to do with the unit.

## 1.2 Importance of the EN 378 series of standards – refrigeration systems and heat pumps – safety-related and environmental requirements

EN 378 deals with safety-related and environmental requirements for designing, constructing, producing, installing, operating, maintaining and disposing of refrigeration systems and cooling equipment.

EN 378 is oriented towards manufacturers, installers and operators of refrigeration systems and cooling equipment (see section 1.2. Responsibilities).

The objective of EN 378 is to restrict the possible hazards of refrigeration systems, cooling equipment and their working fluids (refrigerants and coolants) for people, property and the environment to a minimum.

Insufficient safety measures or non-compliance with safety-relevant regulations can result in:

- Breaks or ruptures on components with the danger of escaping materials (hazards caused by the influence of low temperatures, excess pressure, direct influence of the fluid phase, moving machine parts).
- Escaping working fluid after a break or leak because of defective design, improper operation, insufficient maintenance, repairs, filling and disposal (hazards caused by flammability, explosion hazard, disturbance of nervous system, suffocation, panic)

## 1.3 Responsibilities

### 1.3.1 Manufacturer's responsibilities

The notes provided in these operating instructions on maintaining the unit's functional safety, preventing possible hazards when transporting, setting up and installing, start-up and operation, and with maintenance activities (cleaning, servicing and repairing) refer exclusively to the unit.

The manufacturer's responsibilities are documented in the unit's version in acc. with EN 378-2 (design, manufacture and testing).

The working fluid-carrying parts of the unit (core tubes, distributor tube and header outlet) are configured so that they remain tight with the foreseeable mechanical, thermal and chemical stresses, and withstand the maximum permissible operating pressure.

Material, wall thickness, tensile strength, corrosive resistance, shaping process and testing are suitable for the working fluid used and withstand the possible pressures and stresses that might occur.

All responsibility for the equipment into which the unit is integrated, are the exclusive responsibility of the people involved in the individual workflows.

### 1.3.2 Responsibilities of the system's installer

The responsibilities of the system installer are documented in the system's version (design, manufacture and testing – in accordance with EN 378-2.

Component supplier-system installer interfaces :

- In the event of any malfunction, inform Guntner GmbH & Co. KG :  
Inform Guntner GmbH & Co. KG immediately if faults occur during the set-up, installation, start-up and operation..

The responsibilities of the system installer in particular include:

- Planning and preparing emergency measures:  
To avoid consequential damage caused by operational disruptions, a warning system which immediately signals all faults must be provided on-site. Prepare emergency measures that prevent consequential damage for people and property should faults occur.
- Specify checking and maintenance intervals:  
The system must be configured and equipped with all required equipment for maintenance and sufficient servicing and testing in accordance with EN 378-4.

When the unit is integrated , the working fluid and version must not deviate from the order-related information specified in the order-related documents.

The installer of the system must refer to the requirement for sufficient instruction of the operating and supervision staff when operating and maintaining the equipment .

It is recommended that the future customer staff – if possible – be present during the set-up and installation, for tightness tests and cleaning, while the system is being filled with working fluid and for the adjustment of the equipment .

### 1.3.3 Owner or operator responsibilities

The owner or operator responsibilities are documented in the operation, maintenance, servicing and recovery of the system in accordance with EN 378-4.

The owner or operator must ensure that the proper people are sufficiently trained and qualified for operating, monitoring and servicing the system .

The operating personnel for the system must have sufficient knowledge and experience with regard to the mode of operation, operation and daily monitoring of this system .

Before starting up the system, the owner or operator must ensure that the operating personnel are sufficiently instructed about the system's documentation (which is part of the operating instructions) on the set-up, monitoring, mode of operation and servicing of the system and the safety measures to be observed, and with regard to the properties and handling of the working fluid to be used.

The owner or operator must ensure that when operating, monitoring and maintaining the system the working fluid and version must not deviate from the details specified in the order-related documents.

Planning and preparing emergency measures: To avoid consequential damage caused by operational disruptions, a warning system must be installed on the customer's premises. Prepare emergency measures that prevent consequential damage for people and property should faults occur.

Responsibility remains with the owner or operator of the system , if the system are used by anybody else, unless there is a contrary agreement on sharing responsibility.

If you operate devices that are wetted or sprayed with water, you must observe the contents of the VDI guideline 2047-2 “Requirements for the hygienic operation of cooling towers” and the VDMA leaflet “Notes and recommendations for operating and maintaining evaporative cooling plants”.

## 1.4 Legal notes

---

Warranty claim expires as follows:

- With faults and damages that can be attributed to non-compliance with the specifications of these operating instructions.
- With complaints that can be attributed to use of spare parts other than the original spare parts specified in the order-related offer documents.
- With changes to the unit (working fluid, version, function, operating parameters) vis-a-vis the order-related information specified in the order-related offer documents without the manufacturer's prior consent.

The operating instructions may not be reproduced electronically or mechanically, circulated, changed passed on to third parties, translated or used otherwise, in full or in part, without Guntner GmbH & Co. KG's prior explicit written approval.

## 1.5 Operating instructions

### 1.5.1 Scope

---

#### NOTICE

You will find the precise type of your unit in the attached order-related documents.

### 1.5.2 Set-up and other applicable documents

---

The unit's operating instructions include the following parts:

- These instructions
- Order-related documents  
The order-related documents are included with these instructions and contain the following information:
  - The order-related proper use as specified
  - The order-related scope of delivery
  - The order-related technical data
  - The order-related drawings specifying customer, project number and order number
- Motor connection wiring diagram in terminal boxes

These operating instructions are part of the operating instructions manual of the system, provided by the system's installer .

## 1.6 Conventions

### 1.6.1 Typographical conventions

The following text markups are used in these operating instructions:

<b>Bold</b>	Requires special attention!
Grey triangle	Instructions

### 1.6.2 List of abbreviations

Abbreviations	Meaning
EN 378	European Norm 378: Refrigeration systems and heat pumps; safety-related and environmental requirements
EN	European Norm
DIN	German industrial standard (specification of a standard)
ISO	International Standardization Organization .
°C	Degrees Celsius (Celsius scale temperature)
is	Unit of pressure
l	Litre (liquid volume)
Vol%	Volume percent (concentration level relative to a volume)
IP	Insulation protection
Q 6,3	Balancing quality
ppm	parts per million, concentration figure, stands for "millionth part".
Hz	Hertz (frequency)
D	Delta connection (alternating current: high speed)
S	Star connection (alternating current: low speed)
3~	3-phase current
1~	1-phase alternating current
VDE	"Verband der Elektrotechnik, Elektronik und Informationstechnik" (Association for Electrical, Electronic & Information Technologies)
TCC	Technical Connection Conditions
EPC	Electric Power Company
VDI	"Verein Deutscher Ingenieure" (German engineers' association)



## 1.7 Conventions for safety signs and notices

### 1.7.1 General safety signs and their meaning in these operating instructions

#### **DANGER**

Dangerous situation that will definitely cause serious injury or death if it is not avoided.

#### **WARNING**

Dangerous situation that could cause serious injury or death if it is not avoided.

#### **CAUTION**

Dangerous situation that could cause slight to moderate injury if it is not avoided.

#### **NOTICE**

Refers you to possible damage to property.

### 1.7.2 Warning symbols and their meaning in these operating instructions



#### **Warns against hand injuries!**

Failure to comply with warnings may result in hands or fingers being crushed, dragged in or otherwise injured.



#### **Warns against hot surfaces!**

The temperature is over +45°C (at which protein clots) and can cause burns.



#### **Warns against dangerous electrical voltage!**

Danger of an electric shock if voltage-carrying parts are touched.



#### **Warns against fire-risk substances at set-up point.**

Use of ignition sources can cause fire at set-up point.



**Warns against harmful to health or irritant substances at set-up point**

Contact with or inhaling substances that are irritant or harmful to health can cause injuries or damage peoples' health.



**Warning of automatic start-up**

If the unit starts up automatically during maintenance work there is a danger of pinching/trapping the hands and fingers.

### 1.7.3 Prohibitory signs and their meaning in these operating instructions



**Fire, open fire and smoking prohibited!**

Ignition sources must be kept away and ignition sources must not develop!



**No smoking!**

Smoking is forbidden.

### 1.7.4 Mandatory signs and their meaning in these operating instructions.



**Use eye protection!**

Eye protection: Use protective cover, protective glasses or face protection.



**Use hand protection!**

Protective gloves must protect against mechanical and chemical dangers (see imprinted pictograms).



**Use respiratory protection!**

Breathing apparatus must be suitable for the working fluid used. Breathing apparatus must consist of:

- At least two independent breathing devices (self-contained breathing apparatus)



**Use protective clothing!**

Personal protective clothing must be suitable for the working fluid used and for low temperatures, and must have good heat insulation properties.



**Activate before work!**

Activate the electrical system and secure against switching on again before starting installation, maintenance and repair work.

## 2 Safety

### 2.1 Labelling on the unit:

Identifiers' placed on the unit

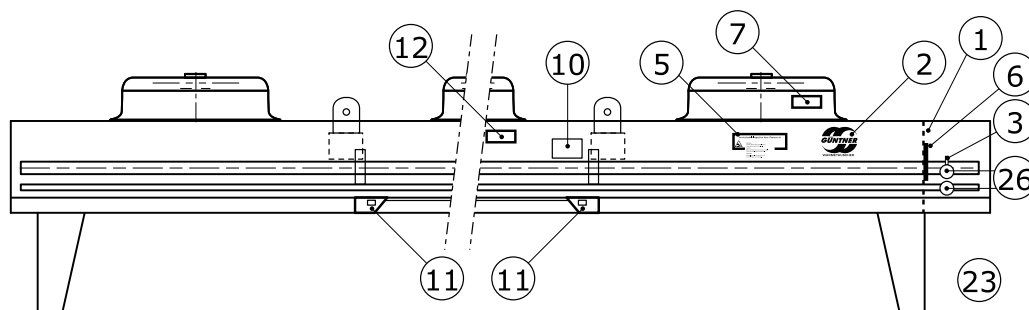

- |   |  |    |  |
|---|--|----|--|
| 1 | Unit type plate on front plate                               | 6  | "Protection grill" warning sign – only with units with individual removable fan protection, e.g. Woods fans.                                 |
| 2 | Güntner logo   | 7  | Connections ON, OFF  |
| 3 | "Transportation filling" warning sign next to Schrader valve | 8  | Transportation regulation; affix on both sides between the lifting lugs; also affix at the front/end sides; and on the packaging if required |
| 4 | Operative range for fork lifts; affix in the struts area     | 11 | Installation instructions for vibration dampers (enclosed with vibration dampers)  |
| 5 | Inspection door, only on units with inspection doors         |    |  |

#### 2.1.1 Safety signs on the unit

Safety signs on the unit individually:

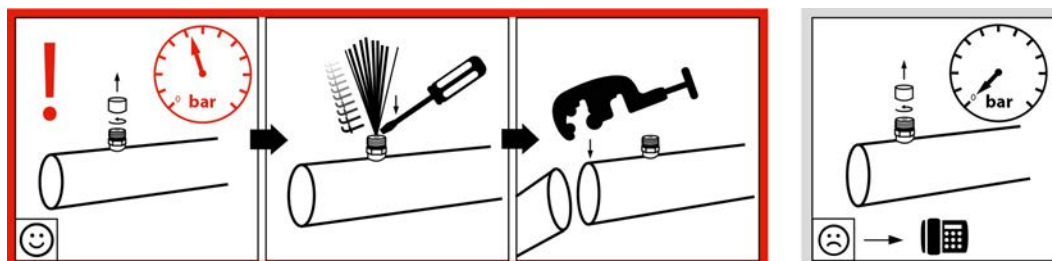

940 - "Transportation filling" warning sign next to Schrader valve

**Achtung • Caution • Attention**

Ventilator-Betrieb nur mit Schutzgitter!

**Gefahr!**

Fan operation only with guard grille!

**DANGER!**

Mode opératoire de ventilateur qu´avec grille protectrice!

**DANGER!**

Art.Code:3083

3083 - "Protection grill" warning sign (only used with separate removable protection grill)



941 - Notice pointing out frost risk

For frost risk [see Frostbite hazard, page \\_\\_\\_\\_\\_](#)

## 2.1.2 Other signs and notes on the unit

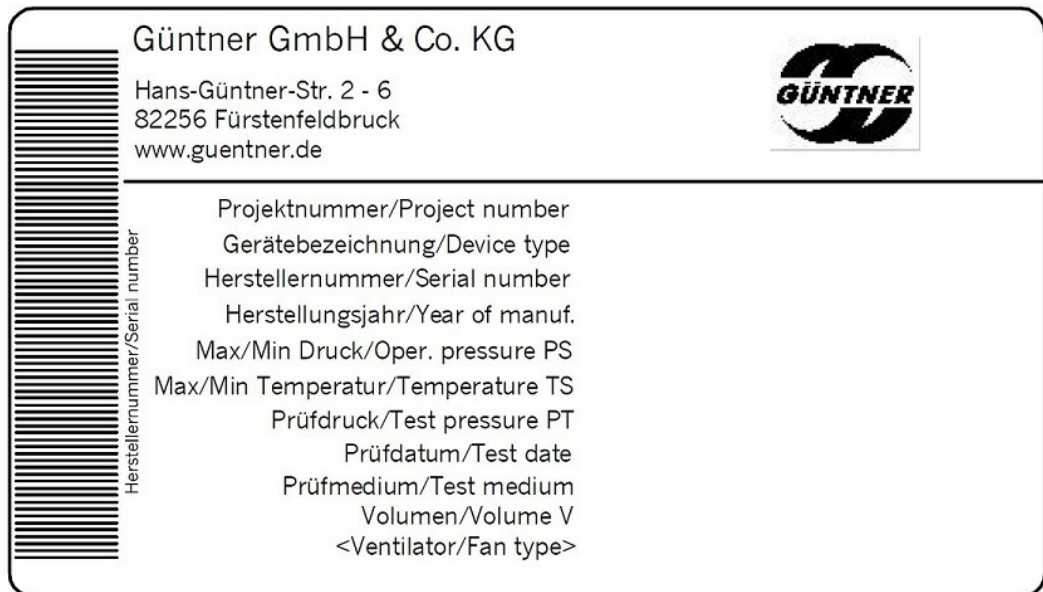

2483 - Example of a manufacturer's nameplate



943 and 943.1 - Connections IN and OUT

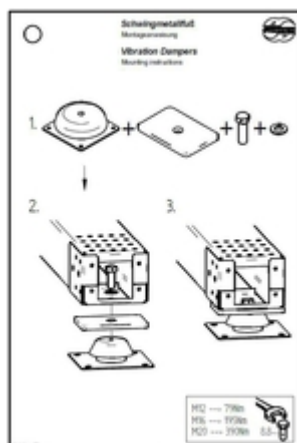

79 - "Vibration dampers" notice

Only for units with the option of vibration dampers; for assembly of the separately enclosed vibration dampers [see Mounting the vibration dampers \(optional\), page \\_\\_\\_\\_\\_](#)

## 2.2 Basic safety notices

### 2.2.1 How to act in an emergency

#### WARNING



Danger of injuries and damage to property!

The unit is operated as standard with the , ethylene glycol (synonyms: ethane-1,2-diol, glycol). When using other , prior agreement with the manufacturer is an absolute must. Ethylene glycol is a colourless, slightly viscous, not very fluid, water-mixable, deliquescent liquid with a sweet smell or taste.



Ethylene glycol is flammable and explosive at higher temperatures in a vapour/ gaseous state.

With skin contact ethylene glycol causes slight irritation with the danger of skin absorption; with eye contact mucous membrane irritation; with ingestion agitation with disruption of the central nervous system; with prolonged endangering effect – fatigue, coordination disruption, unconsciousness, kidney damage.



Keep ethylene glycol away from ignition sources. No smoking!

Ethylene glycol vapours are heavier than air and may flow off to rooms on a lower level. In still air there may be an increase of the ground level concentration. With high concentrations, there is a danger of suffocation due to reduced oxygen concentration, especially at ground level.



Avoid contact with skin, floor, clothing! Remove contaminated, soaked clothing immediately!

Do not allow contact with heavy oxidation agents (chromo-sulphuric acid, potassium permanganate, smoking sulphuric acid, or similar)! Danger of strong reactions!



Unauthorised people must not have access to the unit. When setting up it must be ensured that the escaping from the unit cannot penetrate the interior of the building or put people at risk in any other way.

Safety measures and procedure:

- In the event of serious unexpected leakage of , activate the emergency measures provided, e.g. if:
  - Visibly escaping / from the heat exchanger or pipe components.
  - Sudden large release (release and evaporation of the greater part of the entire / in a short time, e.g. in less than 5 minutes).
- Have experienced, trained personnel with prescribed protective clothing perform all necessary protective and other measures:
  - Use respiratory protection.
  - Use a room air-independent breathing apparatus for maintenance work in high / concentrations in the room air.
  - Ensure the set-up room is well ventilated.
  - Divert escaped / liquid safely in accordance with EN 378-3.



## 2.2.2 Personnel, care requirements

### ⚠ CAUTION

The unit may be installed, put into operation, operated, maintained and repaired only by trained, experienced and qualified personnel. In order to be considered qualified, people who are to be responsible for the operation, maintenance, repair and evaluation of systems and their components must have the necessary training and specialist knowledge for such work, as stipulated in EN 378-1. Qualified or expert means the ability to satisfactorily perform the activities required for the operation, maintenance, repair and evaluation of refrigeration systems and their components.

The unit may be operated by operating personnel that have no specific knowledge of refrigeration engineering, but have sufficient knowledge and experience with regard to the mode of operation, operation and daily monitoring of this system, including the heat carrier circuit. This operating personnel may not make any interventions or settings on the system including the heat carrier circuit.

Changes to the unit, which the manufacturer has first agreed to in writing, may only be made by the instructed and qualified personnel.

Electrical installation:

Work on the electrical equipment may only be performed by personnel that have the required expertise (e.g. an electrician or an electro-technically instructed person), and who are authorised by the operator, in compliance with the respective VDE regulations (and national and international provisions) and the TCCs of the EPCs.

## 2.3 Proper intended use

### 2.3.1 Proper intended use

Dry coolers of the GFH E series are intended for installation in the heat carrier circuit of a refrigeration system and for outdoor installations. The dry coolers cool the heat carrier by giving off heat to the air that is being moved by fans over the dry heat exchanger surface.

The unit is delivered for operation with a specific operating point:

- Heat carrier flow temperature
- Heat carrier return temperature or circulating heat carrier volume
- Airflow volume
- Air inlet temperature

The specified operating point is given in the order-related documents.

### 2.3.2 Operating conditions

The unit is a component of the heat carrier circuit a cooling system including its working fluid circuit. The purpose of these operating instructions, as part of the operating instructions manual (of which these operating instructions are a part), is to minimise the danger to people and property and the environment from the unit and the working fluid used in it. These dangers are essentially connected with the physical and chemical properties of the working fluid and with the pressures and temperatures that occur in the working fluid-carrying components of the unit [see Residual hazards due to the heat carrier glycol, page 20](#).



 **WARNING**

Danger of injuries and damage to property!

The unit may be used only in accordance with the proper intended use. The operator must ensure that when operating, monitoring and maintaining the unit, the fluid used and the mode of operation do not deviate from the order-related information specified in the order-specific documents.

The operator must ensure that maintenance measures are performed in compliance with the system's operating instructions manual.

Filling the unit with a different fluid is permitted only following written approval by the manufacturer. You will find the order-related proper use as intended in the order-specific documents.

Do not exceed the max. operating pressure given on the unit's type plate.

### 2.3.3 Improper use

 **WARNING**

Danger of injuries and damage to property!

Working fluids and their combinations with water or other substances in the working fluid-carrying components have chemical and physical effects from the inside on the materials surrounding them. The unit may be pressurised only with . Pressurising the unit with another working fluid would have the effect that

- material, wall thickness, tensile strength, corrosive resistance, shaping process and testing are not suitable for the working fluid used and do not withstand the possible pressures and stresses that might occur.
- the unit would not be resistant to the other working fluid and the combination of the other working fluid and
- the unit not remaining tight during operation and when shut down.
- a possible sudden escape of working fluids could directly endanger people and/or property and the environment.

The maximum permissible operating temperature specified on the type plate must not be exceeded! If the operating temperature is exceeded,

- the unit would be exposed to an impermissibly high pressure (pressure/temperature correlation),
- signs of material fatigue would emerge,

The maximum permissible operating pressure specified on the type plate must not be exceeded! If the operating pressure is exceeded,

- the parts of the unit carrying the working fluid might not withstand the foreseeable mechanical, thermal and chemical stresses and the pressures that may occur during operation and when shut down,
- the unit would not remain tight during operation and when shut down,
- there may be a possible sudden escaping of working fluids after a break or leakage on working fluid-carrying components, which would result in the following dangers:
  - Danger of escaping materials
  - Strong chemical reactivity
  - hazards caused by panic reactions,
  - Environmental pollution

 **WARNING**

may not be used

- where it is possible that short or prolonged effect caused by contact, inhalation or ingestion of the working fluid glycol might result in harmful hazards.
- where it is possible that the specific concentrations of the coolant in a homogeneous mixture with air could ignite.

The unit must not be changed without the prior written consent of GÜntner GmbH & Co. KG . Changes to the unit are:

- Changing the operating point (as specified in section [see Heat exchanger \(typical values\) , page 26](#))
- Changing the fan capacity (air volume)
- Changing the working fluid flow-through volume
- Changing over to another working fluid

The unit must not be operated if safety devices recommended by the manufacturer are not available, not properly installed or not fully functional.

The unit must not be operated if it is damaged or demonstrates faults. All damage and faults must be reported to GÜntner GmbH & Co. KG immediately and dealt with promptly.

Work on the unit must not be performed without the personal protective equipment specified in these operating instructions.

## 2.4 Mechanical residual hazards

### 2.4.1 Fins, sharp unit corners and edges

 **WARNING**

Warns against hand injuries!

Danger of cuts on hands and fingers on the fins and on sharp corners and edges of the unit.



Use reliable hand protection!

## 2.4.2 Fans

### ⚠ WARNING



Danger of cutting off, pulling in!

There is a danger of cutting off fingers on the rotating fan blades, injury hazard for the hands and pulling in danger for loose elements such as hair, necklaces or clothing parts.



Do not operate fans without guard grille. Pinch/trap point hazard!

With automatic fan start during maintenance work there is a danger of pinching/trapping for the hands and fingers.



Power off the unit before you begin maintenance work with which you must remove the guard grille. Secure the unit against unintentional switching on again by removing the electric fuses for the unit. Secure the unit with a suitable warning sign referring to unintentional switching on.

## 2.5 Electrical residual hazards

### ⚠ WARNING



Warns against dangerous electrical voltage!

Direct and indirect contact with voltage-carrying parts of motors and electrical lines can cause serious injuries or death.



Power off the unit before you begin maintenance work. See the refrigeration system's system documentation for this. Secure the unit against unintentional switching on again by removing the electric fuses for the unit. Secure the unit with a suitable warning sign referring to unintentional switching on.

Please note that the mains cables may also be carrying voltage, even if the unit is powered off.

Work on electrical equipment may be performed only by people that have the required expertise (e.g. an electrician or an electro-technically instructed person) and who are authorised to do so by the operator.

## 2.6 Thermal residual hazards

### 2.6.1 Danger of burns

#### WARNING



Warns against hot surfaces!

When operated the unit's heat exchanger, pipes (hot gas defrost) will be at temperatures of over +45°C. Touching them may cause burns.

Use hand protection!



### 2.6.2 Frostbite hazard

#### WARNING



Warns against cold!

In refrigeration operation the heat exchanger and pipes have a temperature below ±0 °C. Contact can cause frostbite.

Use hand protection!



## 2.7 Residual hazards due to the heat carrier glycol

#### WARNING

Danger of injuries and damage to property!

##### General description of hazards:

The unit is operated as standard with a heat carrier/ (water/glycol mixture – for example, ethylene glycol; synonyms: ethane-1,2-diol, glycol) or with water. When using other heat carriers/, prior agreement with the manufacturer is an absolute must.

Ethylene glycol is a colourless, slightly viscous, not very fluid, water-mixable, deliquescent liquid with a sweet smell or taste.

Unauthorised people must not have access to the unit. When setting up it must be ensured that the heat carrier/ escaping from the unit cannot penetrate the interior of the building or put people at risk.

 **WARNING**

Care must be taken during installation to ensure that no heat carrier/ issuing from the unit can enter water or waste water systems.

Danger of environmental pollution!

Ensure that no heat carrier/ enters water or waste water systems.

 **WARNING**

Danger of harm to health!

With skin contact ethylene glycol causes slight irritation with the danger of skin absorption; with eye contact mucous membrane irritation; with ingestion agitation with disruption of the central nervous system; with prolonged endangering effect – fatigue, coordination disruption, unconsciousness, kidney damage.

- Avoid contact with skin, eyes and clothing! Remove contaminated, soaked clothing immediately!
- Ethylene glycol vapours are heavier than air and may flow off to rooms on a lower level. In still air there may be an increase of the ground level concentration. With high concentrations, there is a danger of suffocation due to reduced oxygen concentration, especially at ground level.
- To avoid the inhalation of high vapour concentrations, the working rooms must be well aired.
- Test the tightness of the unit regularly, as specified in these operating instructions.



Ignition and fire hazard!

Ethylene glycol is flammable and explosive at higher temperatures in a vapour/ gaseous state.

- Keep ethylene glycol away from ignition sources.
- Suitable fire fighting equipment must be provided on site when working with flames, such as grinding or soldering, for example.
- Ensure that the provided fire fighting equipment is provided in sufficient quantities, that it functions properly and that the extinguishing agent does not react with the heat carrier/.
- No smoking!



Danger of poisoning!

Contact of the heat carrier/ with open fire must be prevented, as toxic combustion products can form.

- Prevent heat carrier/ contact with open fire!
- Welding and soldering may therefore take place only after completely draining the relevant section of the system of the heat carrier/. Ensure good ventilation here!
- Do not allow contact with powerful oxidation agents (chromo-sulphuric acid, potassium permanganate, fuming sulphuric acid, or similar)! Danger of strong reactions!





Frostbite hazard!

With insufficient frost protection filling and operation in areas with frost hazard the unit can cause frostbite. With units that cannot be drained completely the hazard of frostbite also remains after draining.

- It is imperative that the proper ventilation be ensured when draining the unit.
- With pressure test, operation and shutdown of units filled with water or insufficient frost protection filling or insufficient setting of the heat carrier/, these are disrupted at minus temperatures.

## 2.8 Residual hazards caused by vibrations

### WARNING

Danger of injuries and damage to property caused by escaping materials!

If fans are damaged during fan operation, flying parts of the fan blades can injure people or cause damage to property close to the fan.

Fans, components and cables in system, must be designed, constructed and integrated so that dangers caused by vibrations that it or other parts of the system generate ,, are reduced to an absolute minimum, while incorporating all available means for reducing vibrations, preferably at the source.

### NOTICE

Damage to property caused by vibrations!

Vibrations that are increased by imbalances, as created by dirt, icing or fan blade damage, are regularly caused with fan operation. The vibrations are transferred to the unit, where they can cause damage and damage the unit mounting or components connected to the unit.

## 2.9 Residual hazards caused by pressurised parts

### WARNING

Injury and damage to property caused by pressurised components that contain !

Breaks in pressurised pipes or pressurised components of the unit can cause injuries or damage to property caused by escaping materials ( A sudden large release of the working fluid with its hazardous properties after a break or leak on pressurised components of the unit can cause the following hazards:

- Flammability
- Suffocation
- Panic,
- Environmental pollution

Ensure that the unit in question is pressure-free before maintenance work begins or remove the working fluid from the unit in question.

## 2.10 Residual hazards caused by defective installation

### WARNING

Injuries and damage to property caused by defective installation!

Defective installation results in hazards caused by:

- Break or leak on liquid-carrying unit components and pipes
- Absence of release devices to prevent liquid escape: Observe the magnet valve/check valve sequence combination in the fluid line: In the flow direction the magnet valve must be installed first and then the check valve. If the sequence is reversed, liquid will be locked in between the check valve and the magnet valve when the magnet valve is closed; this will heat up during shutdown state and can cause pipes or connection flanges to break when it expands. This applies in particular to lines carrying cold liquids.
- Taking the refrigerant pumps out of service: When switching over a duty pump to a reserve pump: If the duty pump is shut off at both ends from the previous operating state, liquid, cold refrigerant remains in the pump. In shutdown state the refrigerant heats up in the pump and causes leaks with housing or flange cracks.
- Uneven load distribution on the fixtures with the danger of stresses within the unit or unit displacement (breaks or leaks on fluid-carrying components of the unit and pipes; danger of breaking off).
- Insufficient securing of working fluid-carrying lines against mechanical damage! On-site connections: loaded installation; effect of forces on the distribution and header pipes with the danger of breaks or leaks on fluid-carrying components of the unit and pipes; danger of breaking off!
- Break-off and fall danger of the unit with hazard of escaping working fluid and exposed electrical cables.
- Danger of damage caused by environment-conditional hazard sources (production, transport and other processes at the set-up point).
- Unit functional faults caused by air inlet/outlet obstructions.
- Obstruction of all-side inspection, checks and maintenance, i.e. no unobstructed accessibility to the working fluid-carrying and electrical components, connections and cables, no recognisable identifiers on the pipes and insufficient space for tests.

Ensure that:

- The units are to be installed on the fixing points corresponding with their weights and tightened with fixing bolts. The operator or installer is responsible for ensuring that the bolted connections are of an adequate strength.
- The diameters of the mounting holes have been statically determined by the manufacturer and the fixing bolts are adapted accordingly.
- The fixing bolts are secured against loosening by means of an appropriate locking device.
- The fixing bolts are not overtightened or stripped.
- All fixing bolts are tightened equally to achieve a load distribution on the connections that is as balanced as possible.
- All fixing points maintain the same spacing to the fixing level permanently and under load, so that no mechanical stress occurs in the unit structure. The units are anchored in their fixing position in order to prevent the equipment from moving.
- The functional safety of the fixing bolts is tested as part of the maintenance periods. [see Maintenance, page 48](#).
- The unit is fixed and set up so that it is not damaged by environment-conditional hazard sources (production, transport and other processes at the set-up point) or its functioning is not disturbed by the interventions of unauthorised persons.
- The units are fixed and set up so that unobstructed air inlet/outlet is constantly available without any air short circuiting.

- The units are fixed so that they can be inspected, checked and maintained from all sides at all times, i.e. there must be unobstructed access to the refrigerant-carrying and electrical components, connections and lines, the pipeline labelling must be identifiable and adequate space must be available for testing.
- The working fluid-carrying lines must be protected against mechanical damage. On-site connections: when installing keep the unit free of load; force must not be exerted on the distribution and header pipes.
- The following must be observed without fail when installing the unit:
  - Imperative adherence to spacing from objects that could be endangered effects.
  - Easily flammable materials must not be placed below the unit.
  - Set up and fix units as follows: In areas that are used for inner-plant traffic, the pipelines to and from the unit must be installed only with connections and fittings that cannot be removed.
  - Release devices to prevent liquid escapes must be provided and available.
  - Subcooled liquid may be present in only the lowest possible amount in system sections in shut-down state – minimized number of “fluid sacks”.
  - That when switching over a duty pump to a reserve pump no liquid, cold refrigerant remains in the pump.

## 2.11 Residual hazards with break during operation

### WARNING

Injuries and damage to property caused by break during operation!

- Defective installation ([see Residual hazards caused by defective installation, page 23](#)).
- Non-compliance with maximum permissible operating pressure ( [see Operating conditions, page 16](#)).
- Disregarding pressurised line sections with maintenance ( [see Residual hazards caused by pressurised parts, page 22](#)).
- Disregarding residual hazards caused by vibrations ( [see Residual hazards caused by vibrations, page 22](#)).

result in ruptures during operation and maintenance. This results in dangers caused by

- escaping materials ([see Residual hazards caused by pressurised parts, page 22](#)).
- released working fluid ([see Residual hazards due to the heat carrier glycol, page 20](#)).

Ensure that:

- The installation is fault-free.
- The maximum permissible operating pressure is always adhered to.
- Pressurised line sections are de-pressurised before all maintenance and repair work.
- Vibrations from the refrigeration system, from the (vibrations caused by system compressors, , components and lines) and from the fan (imbalances caused by frosting, icing or dirt build-up or damages) are reduced with all available means and brought down to an absolute minimum.
- Release devices to prevent liquid escapes are provided and available.
- Undercooled liquid is only present in the lowest possible amount in system sections in shutdown state – minimized number of “fluid sacks”.
- When switching over a duty pump to a reserve pump no liquid, cold refrigerant remains in the pump.



## 2.12 Residual hazards caused by escaping objects or liquids

### WARNING

Injuries and damage to property caused by escaping objects or liquids!

Residual hazards caused by escaping objects and liquids ( [see Residual hazards with break during operation, page 24](#)).

## 2.13 Residual hazards with disposal

### WARNING

Danger of injuries and damage to property caused by working fluid, , , glycol!

The following notes are recommendations for the proper professional disposal of the unit. Applicable waste disposal laws are binding for the country of operation:

- Disposal must only be carried out by experts.
- All unit components, e.g. working fluids, heat exchangers, fans, must be disposed of properly as specified.
- Used working fluid that is not determined for reuse, must be treated as waste and safely disposed of. There must be no emissions into the environment.
- The working fluid must not be filled in a liquid container that contains another or an unknown working fluid. This other or unknown working fluid must not be released into the atmosphere, but rather identified, treated again, or properly disposed of as specified.
- An officially authorised facility can be used for destroying the working fluid.
- It must be ensured that all unit components containing working fluids and are disposed of properly as specified.
- The unit consists predominantly of the basic materials, aluminium, (heat exchangers and casings), steel and aluminium, copper, polyamide (motors), steel, copper, insulating material (heater rods with electric defrosting – option; accessory at customer's request). These materials can be handled by the waste industry, including in paint-treated state, to recycling via mechanical and thermal separation.

### WARNING

Danger of environmental pollution!

Güntner GmbH & Co. KG's transportation packaging is made from environmentally compatible material and is suitable for recycling.

## 3 Technical data

### 3.1 Heat exchanger (typical values)

#### NOTICE

The typical values given here refer to standard types of this series. The following is valid especially for special equipment: Please observe the data in the calculation (Annex) and on the nameplate.

#### NOTICE

The fans' capacity values depend on the ambient temperature and on the air resistance at the set-up point.

Güntner GmbH & Co. KG recommends electric fan ring heating with use in the temperature range.

Please consult the manufacturer when operating the unit below -40°C because of the special material requirements and selection.

All electrical parts must be installed in accordance with EN standards.

Project number	See order-related documents
Unit name	See order-related documents
Manufacturer number	See order-related documents
Production year	See order-related documents
Heat carriers	See order-related documents
Volume	See order-related documents
Maximum permissible pressure (PS)	0 - 10 bar
Permissible operating temperature	See order-related documents
Permissible air humidity	> 100%
Test date	See order-related documents
Test medium	Dry air
Airborne noise emitted	See order-related documents In accordance with the standard procedure for calculating sound level described in EN 13487; Annex C (normative).
Weight	See order-related documents

### 3.2 Fans

The GFH E series uses axial AC fans with 1250 mm diameter.

Fan type	See order-related documents
Current type	Rotating or alternating current
Voltage	400 V 3~ 50 Hz or 230 V 1~ 50 Hz
Balancing quality	Q 6.3 in acc. with VDI 2060

Protective devices	<ul style="list-style-type: none"><li>• Thermal: Thermo-contacts (temperature monitor for safeguarding against thermal overload).</li><li>• Mechanical: Protective contact grille in acc. with EN 294</li></ul>
--------------------	---

## 4 Set-up and function

---

The drycooler consists of,

- a heat exchanger, consisting of tube coils fitted with fins (copper tube, aluminium fin), distribution tubes and header outlets (copper) and tube connections to the tube system,
- a casing consisting of galvanized sheet steel, painted in RAL 7035 (light grey).
- and – depending on the version – with one or more low noise axial fans with maintenance-free motors.

The GFH E series dry coolers are intended for installation in the heat carrying circuit of a cooling system. The cooling system is a combination of fluid-carrying components and fittings connected with one another, which form a closed circuit, in which the fluid circulates.

The heat carrier is the working fluid that is used for the heat exchange, and which remains in the liquid phase during the heat absorption.

The liquid used is a heat carrier in acc. with EN 378-1, para. 3.7.2. There is no imminent danger for the staff.

The heat carrier absorbs heat at a low temperature, heats up, and gives the heat off again at a higher temperature. The dry cooler cools the heat carrier by giving off heat to the air (air-side) that is being moved by fans over the dry heat exchanger surface.

## 5 Fan motor

### NOTICE

During longer periods of storage or standstill, the fans must be activated during 2 to 4 hours per month.

### NOTICE

For fans with the protection rating IP55 or higher, existing closed condensation water holes must be opened at least once every six months.

### AC technology

The AC motors are protected against overheating by a thermocontact (or PTC resistor).

For motors with a thermocontact, the thermocontact must be switched in such a way that the motor cannot be powered on when the thermocontact is triggered. A locking mechanism is recommended to prevent renewed power-on.

Motors with a PTC resistor need an additional external trigger unit for the installed thermistors. A locking mechanism is recommended to prevent renewed power-on. The test voltage at the thermistors is not permitted to exceed 2.5 V, or only current-limiting test devices may be used.

When using a star-delta connection, a corresponding delay must be considered.

For motors with direct starting and a connection value  $> 4.0$  kW, an inrush current limitation (soft start using a thyristor) could be required.

If frequency converters are to be used for speed control, the following points must be considered for external rotor fans:

Between the frequency converter and fans, all-pole sine-wave filters must always be installed (sine wave-shaped output voltage; filter effect between phase to phase and phase to earth).

All Guntner frequency converters are equipped with this function as standard. Conventional three-phase motors are suitable for direct operation with frequency converters.

With star-delta connection, the three-phase fan motors can be operated with two speeds or with speed control. The direction of rotation must be checked. A change in the direction of rotation, if it is wrong, is made by interchanging two phases.

### EC technology

### NOTICE

The fan motors have their own electronic power component. This power component is controlled by means of Guntner Motor Management (GMM). The motors can be operated using single-phase (1~, 200 – 277 V AC, 50/60 Hz) or three-phase (3~, 380 – 480 V AC, 50/60 Hz) voltage ratings. When operated without GMM, the fans should be controlled with a voltage of 0 - 10 V. Refer to the connection plans or the information on the motor terminal box for details on the electrical connection.

## 6 Transportation and storage

### 6.1 Safety

#### WARNING

Crushing danger with falling down!

It can slip and fall off the transporting device, causing serious injuries or death. Heavy impacts or vibrations can damage the unit.

Ensure that the assigned staff is trained for proper unloading.

Ensure that nobody is under the unit or near the loaded area during the transport.

Ensure even weight distribution. Observe that the bulk of the weight is always on the fan side. Observe the transport labels on the packed unit ( [see Other signs and notes on the unit, page 14](#)).

Secure the unit against slipping and mechanical damage.

When transporting by crane: The hooks and lifting gear of the load lifting equipment must be only attached at the points specified by the manufacturer. Ensure that the unit casing is not crushed by slings.

Use auxiliary transport equipment where required. Use a transporting device appropriate for the unit's weight. You will find the weight of the unit in the order-related documents [see Set-up and other applicable documents, page 7](#)). Do not use connection pieces and header pipes as hooking points for lifting, pulling, fixing or mounting. This can cause leaks.

Transport the unit carefully. Particularly avoid setting the unit down hard.

### 6.2 Transportation and storage

#### NOTICE

Read and observe all transport signs on the units' packaging!

- ▶ Use suitable equipment to transport the packed unit to the destination installation site (for example, a crane or fork-lift).
- ▶ Unload the unit.
- ▶

#### WARNING

Danger of damage to goods by falling when transporting by fork-lift!

Packed units that are not lifted with forks of appropriate length could slip and fall.

Only lift the packed unit with a fork-lift with full fork length. Be careful to comply with the positioning specifications for the fork-lift.

Only lift the packed unit with a fork-lift that is appropriate for the unit's weight.

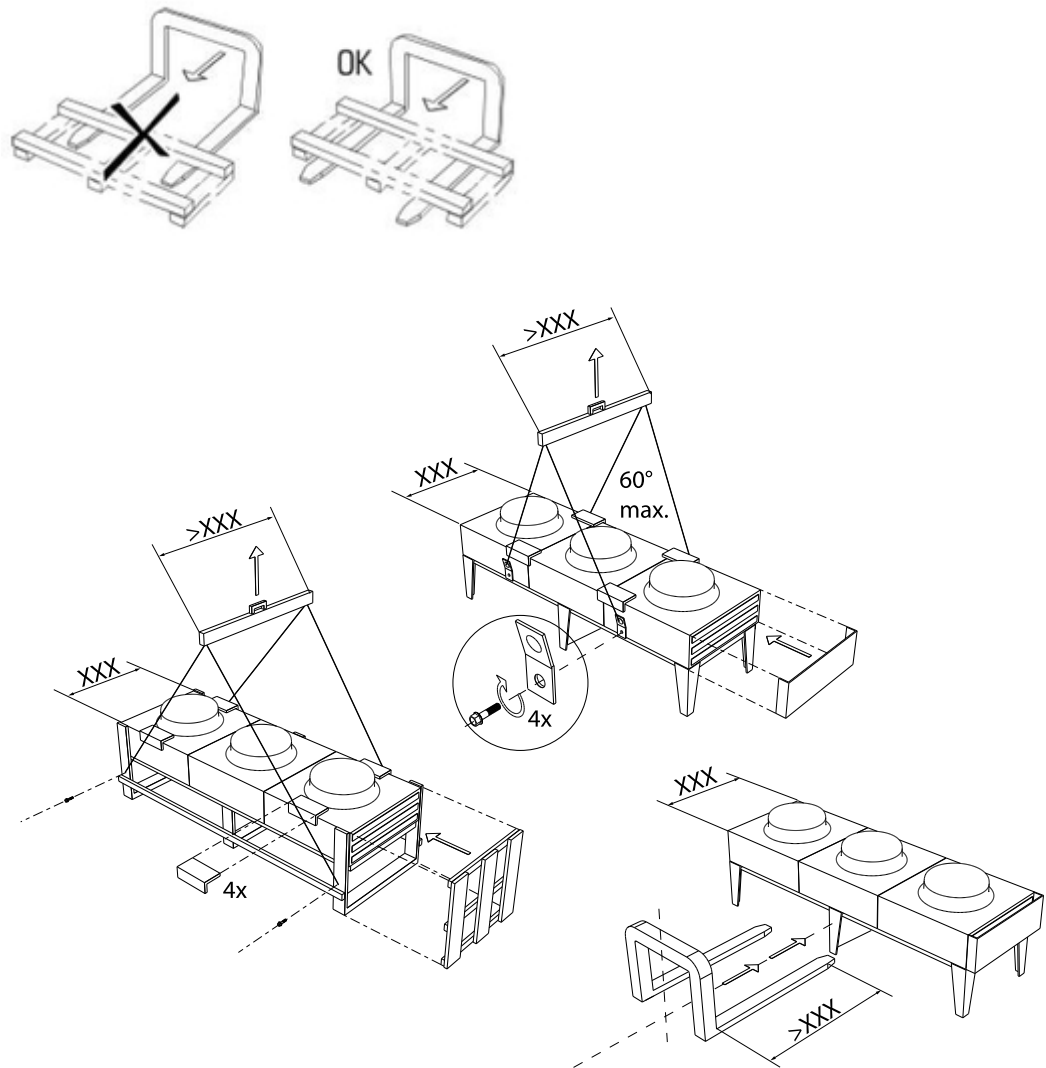

21 - Transport specification for old series

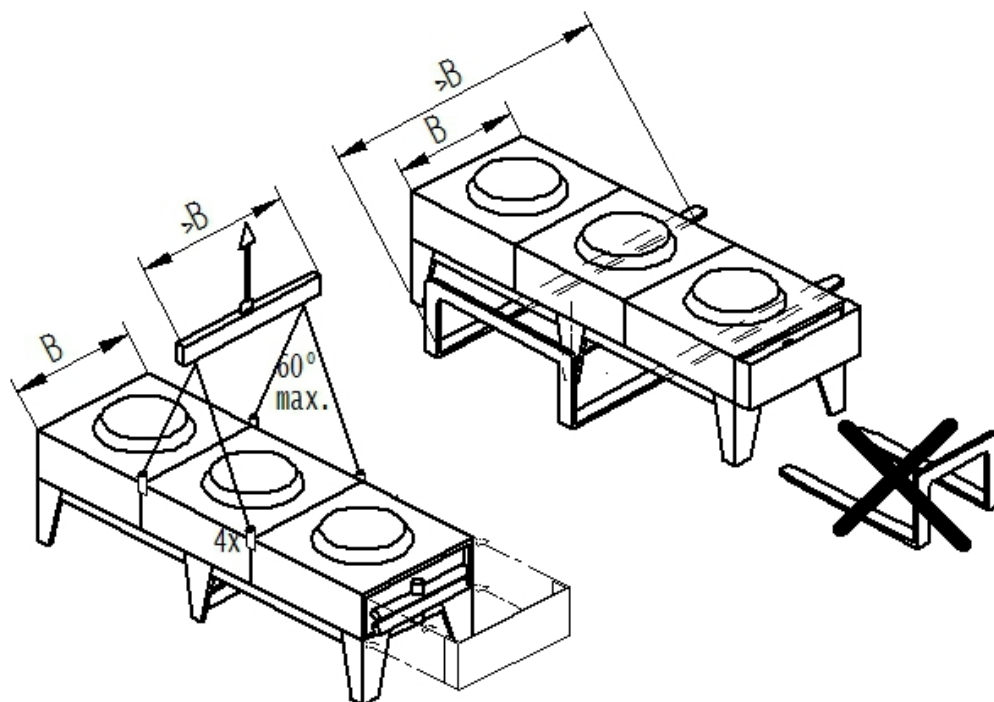

Transport specification for new series

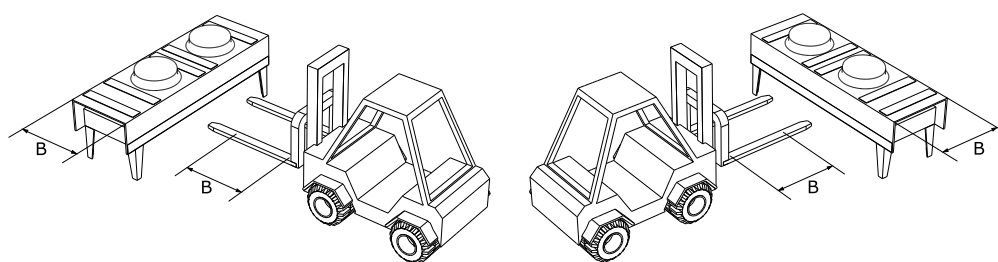

4 - Usage area for forklifts in accordance with SP 34

### 6.3 Storage before installation

#### NOTICE

Danger of corrosion and dirt build-up!

Moisture and dirt must be prevented from entering the unit.

- ▶ Protect the unit against dust, dirt, moisture and wetness, damage and other harmful effects. Harmful effects: [see Safety instructions for set-up and start-up, page 33](#)
- ▶ Do not store the unit for longer than necessary. Only store the units in their original packaging until installation. Always only place packaging units of the same size on top of one another.
- ▶ Store the unit at a protected place free of dust, dirt, moisture and damage-free until its set-up (well-ventilated halls or roofed storage site).
- ▶ If the unit set-up is delayed with regard to the planned installation time: protect the unit against weather and other harmful effects and dirt and other contaminants with an appropriate cover. The unit must also be well-ventilated here.



## 7 Set-up and start-up

### 7.1 Safety

#### 7.1.1 Safety instructions for set-up and start-up

#### ⚠ WARNING

Incorrect installation causes the danger of working fluid escaping when the unit is operated and injuries or damage to property ([see Residual hazards due to the heat carrier glycol, page 20](#)).

Follow the set-up instructions in this chapter precisely and apply extreme care!

#### NOTICE

Damage to the system's !

Foreign materials and contaminants in the working fluid circuit can impair the effectiveness or damage components. Particularly harmful contaminants are:

- Moisture
- Atmospheric air
- Rust
- Soot/ash/cinders
- Metal cuttings
- Dust and dirt of all kinds

Moisture in the working fluid-carrying components of the unit can have the following consequences:

- Changing the prescribed concentration of heat carrier corresponds to an increased danger of too little frost protection in the dry cooler, which could result in the unit being destroyed when subjected to minus temperatures.

Atmospheric air and other non-condensable gases can have the following consequences:

- Changing the concentration of heat carrier corresponds to an increased danger of too little frost protection in the dry cooler, which could result in the unit being destroyed when subjected to minus temperatures.

Other contaminants can cause:

- Accelerated chemical processes (decomposition)

During the installation (connecting the working fluid-carrying components of the unit to the working fluid-carrying system of the installation's ensure that internal contamination is strictly avoided.

Perform the installation with extreme cleanliness.

Finish all on-site pipe installation work before releasing the transport pressure!

Only release the transport pressure on the Schrader valve immediately before installation.

Only remove the sealing caps on the distribution and header pipe immediately before installation.

#### NOTICE

Danger of corrosion and dirt build-up!

Moisture and dirt must be prevented from entering the unit. If moisture and dirt penetrate the unit there is also the danger of damage to fittings and other system components of the .

Protect the unit against dust, contamination, moisture and wetness, damage and other harmful influences. Harmful influences are, for example:

- Mechanical: Damages caused by impacts, objects falling on or against, collisions with transport equipment, etc.
- Physical: Damages caused by close by concentrated flammable gases
- Chemical: Damages caused by contaminated atmospheres (salt, acid, chlorine, sulphur-containing, or similar)
- Thermal: Damages caused by close by heat sources

Begin with the installation as soon as possible.

### **WARNING**

The electrical installation may be performed only by electricians (or by expert technicians with appropriate qualifications) in compliance with the relevant VDE rules (or applicable national and international regulations) and the TCCs of the EPCs!

## 7.1.2 System-side safety requirements

The unit is a component of an installation and can only be operated in conjunction with the installation

- All equipment required for operating the unit must be integrated into the switching and activation equipment :
  - Electrics: Fans and other electrical components, heating rods for electrical defrosting (optional) if applicable,
  - Working fluids: valves and fittings
  - Drip water: drip water drain line
- The power supply of the fans must be provided in acc. with the specifications on the type plate on the fan motors.
- A switch-off device for preventing unexpected start-up (repairs switch), which separates all active conductors from the power supply (all-pole switch-off), must be provided for the fans in acc. with EN 60204-1.
- The fans' switch-on/off device must be secured (e.g. with a padlock) to prevent uncontrolled fan start-up.
- The electrical motor, repairs switch, terminal box and switching cabinet connections must be provided in acc. with the respective connection diagrams.
- It must be possible to shut off the unit if a leak occurs.
- People wearing ambient air-independent breathing apparatus in full protective clothing must also be able to activate all safety-relevant shut-off fittings.
- It must be possible to activate all devices meant for diverting escaping working fluids from a safe position.

### 7.1.3 Customer-side safety precautions

#### ⚠ WARNING



Danger of injuries!

The unit contains (see [Residual hazards due to the heat carrier glycol, page 20](#)).

The unit is operated as standard with the , ethylene glycol (synonyms: ethane-1,2-diol, glycol). Prior agreement with the manufacturer is imperative when using other coolants.



Ethylene glycol is a colourless, slightly viscous, not very fluid, water-mixable, deliquescent liquid with a sweet smell or taste.

With skin contact ethylene glycol causes slight irritation with the danger of skin absorption; with eye contact mucous membrane irritation; with ingestion agitation with disruption of the central nervous system; with prolonged endangering effect – fatigue, coordination disruption, unconsciousness, kidney damage.



Ignition and fire hazard! Ethylene glycol is flammable and explosive at higher temperatures in a vapour/gaseous state. Keep ethylene glycol away from ignition sources. No smoking!

Ethylene glycol vapours are heavier than air and may flow off to rooms on a lower level. In still air there may be an increase of the ground level concentration. With high concentrations, there is a danger of suffocation due to reduced oxygen concentration, especially at ground level.

Avoid contact with skin, eyes and clothing! Remove contaminated, soaked clothing immediately!

There is no imminent danger for the staff.

Do allow contact with heavy oxidation agents (chromic-sulphuric acid, potassium permanganate, smoking sulphuric acid, or similar)! Danger of strong reactions!

Unauthorised people must not have access to the unit. When setting the unit up it must be ensured that the coolant escaping from the unit cannot penetrate the interior of the building or put people at risk in any other way.

Comply with the requirements of EN 378-3 for coolants, filling weight and cold transfer systems.

Only install the unit in accordance with EN 378-1 in the commissioned configuration and only in a set-up room that the unit manufacturer has configured the unit for.

Install the unit in accordance with EN 378-3, section 5 in a special machine room if a coolant concentration of more than that specified in EN 378-3 could endanger the work environment. Take effective protective precautions if such a spatial separation were to be required, but is not possible.

Install the electrical equipment (for fan operation, for ventilation, for lighting and for the alarm system) in the set-up room while observing the condensing-out of moisture and drip water formation, as well as the risk level of the coolant in accordance with EN 378-3; section 6.

Arrange alarm systems to warn about explosion or fire dangers or ammonia concentrations that are hazardous to health and for control purposes in the unit set-up room in accordance with EN 378-3; section 7.

Ensure that the device in the set-up room is not exposed to any inadmissible high temperature effects. Effectively protect the unit against heat sources or temporary high temperatures.

### **WARNING**

Danger of environmental pollution!

## 7.2 Requirements at the set-up point

You will find the dimensions and weights in the order-related documents.

- ▶ Position the unit so that it cannot be damaged by internal traffic or transport processes.
  
- ▶ Enable optimum unit control and accessibility:
  - Place the unit so that it can be monitored and controlled from all sides at all times.
  - Ensure that sufficient space is provided for maintenance.
  - Ensure that all liquid-carrying components, connections and lines and all electrical connections and lines are easy to access.
  - Ensure that there is free space for the unobstructed exchange of heater rods for electric defrosting.
  - Ensure that the pipes' identification is well visible.
  - Ensure that units with electric block defrosting have enough space for changing heater rods.

### **NOTICE**

#### **Danger of rusting of the vibration dampers or unit feet.**

Installation of the unit in stagnant water or on surfaces on which water can collect (such as glycol protectors) can lead to rust on vibration dampers and unit feet.

Rusting vibration dampers or unit feet can cause instability of the unit.

## 7.3 Unpacking the unit

- ▶ Check the delivery for completeness. You will find a list of the contents of the package in the order-related documents.
- ▶ Any transport damage and/or missing parts must be recorded on the bill of delivery. The facts must be immediately reported to the manufacturer in writing. Damaged fins can be straightened on-site with a fin comb.
- ▶ The units are delivered packed in the installation position.
- ▶ Check transport overpressure: The units are delivered from the manufacturer with approx. 1 bar transport overpressure (cleaned and dried air). Read the transport pressure on the Schrader valve (pressure measurement). With unpressurised unit: Immediate report to manufacturer and noting on bill of delivery. An unpressurised unit indicates a leak on the unit!  
**CAUTION! Danger of injuries and damage to property with escaping working fluid!**  
**An unpressurised unit indicates a leak due to transport damage. Escaping working fluid through leaks on the unit can cause injuries or ( see [Residual hazards due to the heat carrier glycol, page 20](#)). Do not put the unit into operation!**
- ▶ Check transport pressure and release (only immediately before installation).
- ▶ Remove blanking plugs.

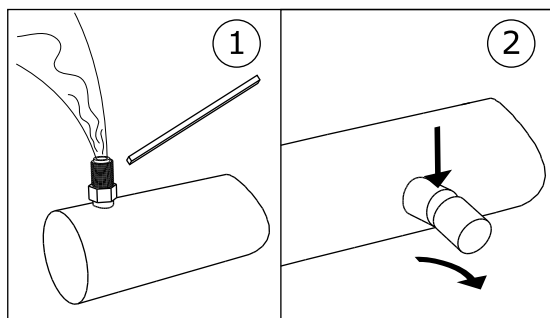

1: Check/release transport overpressure / 2: Remove blanking plugs.

## NOTICE

Danger of corrosion and dirt build-up!

Moisture and dirt must be prevented from entering the unit.

Protect the unit against dust, dirt, moisture and wetness, damage and other harmful effects. Harmful effects: [see Safety instructions for set-up and start-up, page 33](#)

Begin with the installation as soon as possible.

## 7.4 Installation

### 7.4.1 System-side requirements for stress-free installation

- ▶ Prevent stresses in the unit:
  - Ensure that all fixing points have the same spacing to the fixing level.
  - Ensure that all fixing points maintain the same spacing to the fixing level under load and permanently.
- ▶ Set up and fix units as follows: Airflow must not be impaired by obstructions.

- ▶ The units must be installed on fixing points that are appropriate for the unit's weight and then bolted with fixing bolts. The operator or installer of the equipment is responsible for ensuring that the bolted connections are of an adequate strength. The following instructions must be observed when fixing the units:
  - The diameter of the mounting holes have been statically determined by the manufacturer; the fixing bolts must be adapted accordingly. When calculating the transferring bearing strength it is imperative to take into account the total weight of the unit (= structural weight + weight of pipe content + additional weight, such as water, frost, ice, dirt or similar).
  - The fixing bolts must be secured against loosening with an appropriate locking device.
  - The fixing bolts must not be overtightened or stripped.
  - All fixing bolts must be tightened equally.
- ▶ Prevent the unit from shifting in its position. Fix the unit in its position. Tighten the fixing bolts and secure then against loosening.
- ▶ Ensure that the drip water drains correctly. Set up the unit horizontally with a sufficient slope for the drip water run-off. The units are delivered in the installation position with mounted drip tray.
- ▶ Only fix the unit to the intended fixing points.

## 7.4.2 Mounting the unit

## 7.5 Notes on connecting the unit

### WARNING

Danger of injuries and damage to property caused by escaping .

Incorrect installation risks working fluid escaping when the unit is operated, causing injuries or damage to property ([see Residual hazards due to the heat carrier glycol, page 20](#)).

Prevent working fluid from escaping from the unit into the environment.

- Secure all working fluid-carrying lines against mechanical damage.
- In areas that are used for internal traffic, only lay the pipelines to and from the unit with connections and fittings that cannot be removed.

Ensure that the on-site connections do not exercise any forces upon the distribution and header points. This can cause leaks on the working fluid connection points of the unit and on connection points of the on-site pipe-laying.

Ensure that:

- Release devices to prevent liquid escapes are provided and available.
- With refrigeration system shutdown state, under-cooled liquid is only present in the lowest possible amount in system components – minimized number of "fluid sacks".

### 7.5.1 Connect the unit to the system

### WARNING

Danger of injuries and damage to property!

Improper connection to the the system causes hazards:

- Leaks result in escaping ([see Residual hazards due to the heat carrier glycol, page 20](#)).
- Smoking or open light can cause fires or explosions.

- Ensure that stresses and vibrations from the system are not passed on to the unit.
  - Only lay working fluid-side connections stress-free! The on-site pipeline system must be braced before connecting to the unit!
  - Evacuate the unit professionally in acc. with EN 378-2.
  - The use of open fire at the installation site is forbidden. Fire extinguishers and extinguishing agents used to protect the equipment and the operating staff must comply with the requirements of EN 378-3.
- Install the pipes in acc. with EN 378-1 and EN 378-3. Ensure here:
- Avoid transmitting vibrations to the unit via conduits or pipes. If necessary, use vibration dampers.
  - Route the return line with a continuous gradient of from 3 to 5° along the direction of flow. Make sure it can drain freely into the expansion tank!

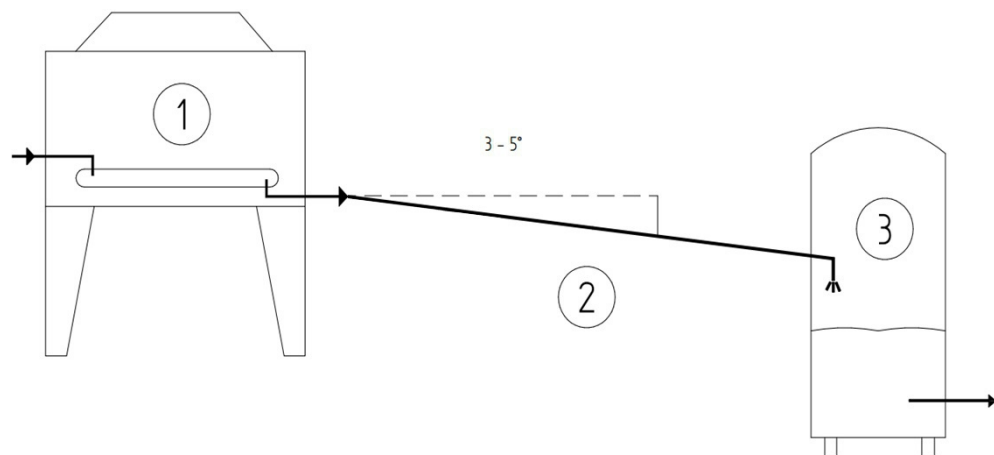

(1) Dry cooler

(3) Free flow

(2) Return line (routed with a gradient)

- Always lay the fluid supply and return lines separately from one another. Make sure they do not touch.
  - Always lay fluid supply and return lines separately from one another.
  - The free space around the unit must be big enough to ensure there is no danger to the unit; regular maintenance of the components must be possible, and it must also be possible to check and repair components, pipes and fittings.
  - It must be possible to shut off the unit if a leak occurs. It must be possible to activate all devices used for diverting escaping working fluids from a safe position.
- Ensure that the unit is well ventilated.
- Provide all bleed connections on the deflected collector with automatic bleed valves.
  - When you do so, make sure that you do not restrict the cross section of the bleed connections.
- Prevent the bleed mechanism from freezing:
- Provide the bleed valves and bleed connections with auxiliary heating. Make sure the auxiliary heating will always be in operation when the outside temperature is  $<+ 3^{\circ}\text{C}$ .
  - Insulate the bleed valves and bleed connections. Make sure the insulation does not affect the operation of the automatic bleed valve.

## ⚠ WARNING

Risk of damage from inadequate ventilation!

Without proper ventilation, the unit can be damaged or destroyed by freezing liquid.

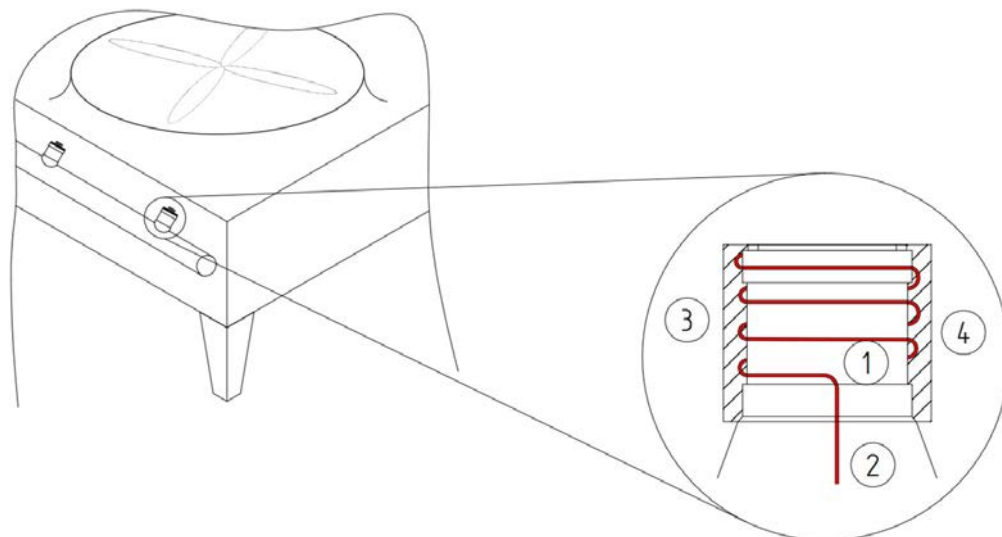

(1) Automatic bleed valve

(2) Bleed connection

(3) Auxiliary heating

(4) Insulation

## 7.5.2 Unit electrical connection and protection

All fans with rotating current drive can be operated via D-S switch-over with two different speeds:

- D: high speed
- S: lower speed
- ▶ Connect fan motors in acc. with motor connection circuit in terminal box or electric diagram and check connection.
- ▶ Provide power supply in acc. with the specifications on the fan motor's type plate or electric diagram:
- ▶ Necessary for the protection of the fans: Connect and evaluate thermo contacts for motor protection if they are there.
- ▶ Where required, connect electrical feeds for the heater rods for electric defrosting in accordance with electric connection diagram.



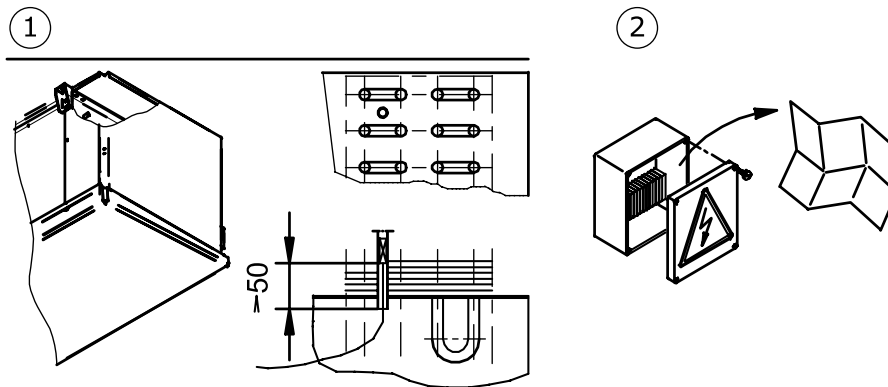

- 1 Defrost limit sensor position (if used)  
 2 Electrics (fan motor, stamp data, connection values)

- ▶ Seal all electrical lines to the connection boxes in acc. with EN60204-1 and their protection class. Make sure the IP protection class is paid heed to. Pay heed to information on the electric diagram. The protection class is specified in the chapter "Technical data - Fans".

### ⚠ WARNING

**Danger of damaging! If the fuse rating is too high there is the danger of injuries to people and damage to property.**

**Max. fuse rating for the defrost heater rods feed : see order-related offer documents.**

## 7.6 Perform acceptance test

### ⚠ WARNING

Danger of injuries and damage to property!

Escaping can cause injuries or even death ( [see Residual hazards due to the heat carrier glycol, page 20](#)).

Perform the following acceptance test with an expert before starting up the unit after making important changes and after a unit exchange.

- ▶ Ensure that the temperature and air humidity at the set-up point are in line with the technical data ([see Technical data, page 26](#)).
- ▶ Ensure that sufficient air can be sucked in and released.
- ▶ Ensure that the supply feed is sufficient for the required energy. Compare the unit inside of the system with the plans of the system and the electrical wiring diagrams.
- ▶ Test the unit for vibrations and movements that can be caused by the fans and operation of the system . Remove oscillations, vibrations and movements following consultation with the manufacturer or independently.
- ▶ Perform visual inspection of the structural design, the brackets and fixtures (materials, sequence, connections), the ability to operate and the arrangement of the fittings.
- ▶ Check and if necessary re-tighten all threaded connections, especially on the fans.
- ▶ Check installation of pipe connections.
- ▶ Check laying of working fluid-carrying connection pipes.
- ▶ Ensure that the unit is protected against mechanical damage.

- ▶ Ensure that the unit is protected against inadmissible heating up and cooling down.
- ▶ Check the fan blades protection.
- ▶ Ensure that optimum unit control and accessibility are guaranteed.
  - Is the unit placed so that it can be monitored and controlled from all sides at all times?
  - Is sufficient space provided for maintenance?
  - Are all liquid-carrying components, connections and lines and all electrical connections and lines easy to access?
  - Are the pipes easy to identify?
- ▶ Check heat exchanger surfaces for dirt and clean as required ([see Clean unit, page 51](#)).
- ▶ Perform function tests on the fans (rotation direction, power consumption, etc.).
- ▶ Check electrical connections of the fan motors and, where app., the heater rods with electric defrosting for damage.
- ▶ Perform pressure test with test gas and with a test pressure of 1.1-times the permissible operating pressure: check the connection seals and detect leaks, e.g. with foaming agent, or similar.
- ▶ Check corrosion protection: Perform a visual inspection on all bends, components and component holders that are not heat-insulated. Document and archive test results.
- ▶ Perform test run. Observe and check unit during test run, in particular for:
  - Fan smooth running (bearing noises, contact noises, imbalances, etc.).
  - Fan power consumption:
  - Leaks
- ▶ Report all defects to the manufacturer immediately. Remove defects following consultation with the manufacturer.
- ▶ Check the unit and the unit's interaction with of the system again after 48 operating hours, especially on the connections and on the fans, and document the test results.

## 7.7 Test readiness for operation

- ▶ Ensure that all electrical protective measures are ready to function.
- ▶ Ensure that all working fluid-carrying connections are securely in place.
- ▶ Ensure that all electrical connections (fans , if applicable heater rods for electrical defrost ) are effected securely.

## 7.8 Putting the unit into operation for the first time

### ⚠ WARNING

Danger of injuries and damage to property!

Escaping can cause injuries or even death ( [see Residual hazards due to the heat carrier glycol, page 20](#)).

You can put the unit into operation, only when:

- The unit has been properly mounted and connected ( [see Installation, page 37](#)).
- You have performed a complete acceptance test ([see Perform acceptance test, page 41](#)).

- You have checked the unit's readiness for operations (see [Test readiness for operation, page 42](#)).
- All safety precautions (see [Safety, page 33](#)) have been taken.

Follow the operating instructions manual of the system!

Contact the manufacturer immediately if you want to operate the unit under different operating conditions as those defined in the order-related offer documents.

- ▶ Switch on the system including of the electrical system (see system).
- ▶ Activate the unit:
  - Open the valves on the inlet and outlet-side system.
  - Activate fans
- ▶ Wait until the operating point is reached. After the operating point is reached the unit is ready to operate (see system).

Parameters for setting the operating point, see order-related offer documents.

Operating point:

- Heat carrier flow temperature
- Heat carrier return temperature or circulating heat carrier volume
- Airflow volume
- Air inlet temperature

To ensure the specified operating point is complied with the actuators for the operating point setting must be secured against unauthorized access (e.g. by sealing, screwing on caps, removing hand wheels, etc.).

## 8 Operation

### 8.1 Safety

#### WARNING

Danger of cutting off, pulling in!



There is a danger of cutting off fingers on the rotating fan blades, injury hazard for the hands and pulling in danger with loose elements such as hair, necklaces or clothing parts.

Do not operate fans without guard grille!

#### WARNING

Danger of frostbite/burning!



Danger of frostbite or burns if the parts are touched ( [see Thermal residual hazards, page 20](#)).

Do not touch any parts of the unit without protective gloves when the unit is in operation or if it has not yet warmed up or cooled down after operation.



### 8.2 Putting the unit into operation

To operate the unit the system including the electrical system must be in operation. The unit must be started up by opening the valves on the inlet and outlet side of the plant by connecting it to the electrical system and the drip water drain as described below (see system operating instructions manual):

- ▶ Switch on electrical system
- ▶ Open working fluid-carrying lines
- ▶ Switch on fans
- ▶ Put drip water waste line into operation

### 8.3 Taking the unit out of operation

- ▶ Switch fans off
- ▶ Switch electrical system off
- ▶ Close working fluid-carrying lines

- ▶ **NOTE!** When shut down consider max. operating pressure! If necessary, take precautions to ensure that it cannot be exceeded, or drain the device.

### NOTICE

With shutdown times of a month or longer put the fans into operation for approx. 2-4 hours a month to maintain their functionality.

## 8.4 Shutting the unit down

### ⚠ WARNING

Danger of injuries and damage to property!

Escaping can cause injuries ( see [Residual hazards due to the heat carrier glycol, page 20](#), and see [Residual hazards caused by pressurised parts, page 22](#)).

Ensure that the maximum operating pressure is not exceeded after the shutdown either!

### NOTICE

Danger of corrosion and dirt build-up!

Moisture and dirt must be prevented from entering the unit.

Protect the unit against dust, contamination, moisture and wetness, damage and other harmful influences (see [Safety instructions for set-up and start-up, page 33](#)).

With shutdown times of a month or longer put the fans into operation for approx. 2-4 hours a month to maintain their functionality.

- ▶ Take the unit out of operation (see [Taking the unit out of operation, page 44](#)).
- ▶ Secure the unit:
  - When shutdown consider max. operating pressure (see [Technical data, page 26](#))! If necessary, take precautions so that it cannot be exceeded.
  - Secure the fan motor drives and, where applicable, the heater rods with electric defrosting against switching on again.
  - Secure working fluid-carrying lines against pressurizing with working fluid.
  - Protect against damaging effects at the set-up point or intermediate storage location (see [Safety instructions for set-up and start-up, page 33](#)), so that the unit's components are kept properly looked after and the proper intentional use and usability of the unit are maintained. The corresponding storage conditions must be provided for this (see [Storage before installation, page 32](#)); precautionary corrosion protection measures, regular checking of the fans' functionality and regular checks on the shutdown unit.
- ▶ Drain the unit: Completely release (see [Residual hazards with disposal, page 25](#)).

## 8.5 Putting the unit into operation after a shutdown

The unit must be put back into operation after a shutdown in acc. with the system-specific set-up in acc. with the operating instructions manual as follows:

- ▶ Test the unit's readiness for operation ([see Test readiness for operation, page 42](#)). Perform pressure test and visual inspection for corrosion protection.  
**NOTE! The pressure test with recommissioning must only be carried out with appropriate media at appropriate test pressure.**
- ▶ Put the unit into operation ([see Putting the unit into operation, page 44](#)).

## 8.6 Changing the unit over to another working fluid

### WARNING

Danger of injuries and damage to property!

Considerable dangers can be caused with operation with another working fluid without prior manufacturer approval ([see Improper use, page 17](#)).

Without prior written consent from Guntner GmbH & Co. KG, the unit must not be changed over to use a different working fluid.

- ▶ Ensure that the unit manufacturer has agreed to the changeover.
- ▶ Ensure that the right working fluid is re-filled. Ensure that all materials used in the unit are compatible with the new working fluid.
- ▶ Ensure that the permissible pressure is not exceeded.
- ▶ Check that the new working fluid can be used without requiring a new test certificate for the unit. Ensure that classification is complied with.
- ▶ The safety device for the unit must be swapped out or reset.
- ▶ Mixtures with residues of working fluid, for example, must be prevented.
- ▶ All information concerning the new working fluid must be changed accordingly.
- ▶ The complete documentation, including these operating instructions and the system operating instructions manual must be changed accordingly.
- ▶ Perform acceptance test ([see Perform acceptance test, page 41](#)).

## 9 Troubleshooting

### 9.1 Safety

#### ⚠ WARNING

Danger of injuries and damage to property!

Faults that are not described in these operating instructions may be resolved only by GÜNTNER. Contact the GÜNTNER hotline.

Faults that are described in these operating instructions must only be removed by appropriately trained personnel ([see Personnel, care requirements, page 16](#)).

If any faults occur during the operation, monitoring or maintenance of the system as a whole, inform GÜNTNER GmbH & Co. KG immediately.

### 9.2 Service

#### Office hours

Tel. +49 8141 242-473

Fax. +49 8141 242-422

Email: [service@guentner.de](mailto:service@guentner.de)

Mon-Thurs: 7.30 am - 5 pm

Fri: 7.30 am - 1.30 pm

### 9.3 Troubleshooting table

Fault	Possible cause(s)	Remedy
Fan motor not running	Power supply interrupted	Restore power supply
	Fan blade stuck	Enable fan to rotate freely
Bearing noises	Defective fan motor	Renew bearing or fan motor
Unit vibrating	Defective fan blades	Change fan blades
	Loose fan fixture	Tighten fixtures
Unit capacity not achieved	Heat exchanger is very dirty, frosted, iced on the air side	Clean, defrost heat exchanger
	Fans not running properly or down	Repair, exchange fans
	Working fluid pressurising defective (temperature and quantity insufficient)	Set working fluid pressurising values (temperature and quantity) to reference values.
Working fluid escaping	Unit working fluid-carrying components leaking	Switch off working fluid feed and fans, close leak

## 10 Maintenance

### 10.1 Safety

#### 10.1.1 Before starting all maintenance

#### WARNING

Danger of injuries and damage to property with escaping working fluid! [see Residual hazards due to the heat carrier glycol, page 20](#)).

Perform the following safety measures before beginning all maintenance work:

- Evacuate/ the unit's heat exchanger
- Clean and blow out the unit's heat exchanger.

#### 10.1.2 With all maintenance work

#### WARNING

Danger of injuries and damage to property with escaping working fluid! [see Residual hazards due to the heat carrier glycol!](#)

Escaping working fluid with leaks on the unit can cause the following hazard situations and injuries:



- Use eye protection!



- Use hand protection!

- Ensure that the unit in question is pressure-free before maintenance work begins or the working fluid is sucked up from the unit in question.
- Power off the electrical system and secure it against unintentional switching on again.
- Separate the unit to be maintained from the of the system and secure it.

#### NOTICE



Danger of damage to property!

With work in the inlet and outlet feeds of the fans and heat exchanger, objects can get into the fans and therefore cause faults and damage on the components.

- After the work has finished do not allow any objects to get back into the inlet and outlet feeds of the fans or the set-up room.



### 10.1.3 After all maintenance work

#### ⚠ WARNING

Danger of injuries and damage to property caused by escaping ( [see Residual hazards due to the heat carrier glycol, page 20](#) )!

Perform the following safety measures after finishing all maintenance work:

- Ensure the switching and activation devices, the measuring and display devices and the safety devices function properly.
- Ensure the working fluid fittings are functioning.
- Check the identification of the pipelines and ensure this is visible and legible.
- Check the fixing and corrosion protection of the components in question.
- Ensure the electrical connections (e.g. fans) are functioning.
- Ensure the temperature and air humidity at the set-up point are the same as that in the order-related offer documents.
- Perform a pressure test and a tightness test (see operating instructions manual annex).
- Perform an acceptance test ( [see Perform acceptance test, page 41](#) ).
- Perform a pressure test (see operating instructions manual annex).

## 10.2 Inspection and maintenance plan

The checks to be performed are listed in the following sections as time-scaled checklists.

### 10.2.1 Fans

The manufacturer's operating specifications take priority for this component. Güntner GmbH & Co. KG recommends proceeding according to the following inspection and maintenance plan:

d = daily, w = weekly, m = monthly, y = yearly				
Work to be performed	d	w	m	y
Check the fan drive for smooth running. • Vibrations on the unit: remove imbalances • Where required, tighten and correct blade fixtures and blade settings				X *
Fan bearing: Running sound and smoothness changes • Exchange bearing				X *
Fan motor: Is a new bearing due? • Exchange bearing or motor; where applicable, clean and repair motor				X *
Fan wheel: corrosion on bolts (with threaded blades) • exchange bolts				X *
Fan blades: Corrosion or damage on blades • Exchange blades or wheel				X *

\*) Recommended: every six months

## 10.2.2 Unit heat exchanger

### ⚠ WARNING

Danger of injuries and damage to property caused by escaping ( [see Residual hazards due to the heat carrier glycol, page 20](#))!

d = daily, w = weekly, m = monthly, y = yearly				
Work to be performed	d	w	m	y
Check heat exchanger for dirt build-ups. • With dirt build-ups: Clean heat exchanger ( <a href="#">see Clean unit, page 51</a> ).				X*
Check heat exchanger's general condition. • Damage found: Repair damage				X*
Check heat exchanger's operating point ( <a href="#">see Operation, page 44</a> ). • Change in fan capacity found: restore required system-side conditions . • Change in surface temperatures found: restore required system-side conditions .				X*
Change in heat exchanger setting found: restore required heat exchanger setting (concentration, inhibition)				X*
Check heat exchanger and connections for tightness. • Repair unit sections ( <a href="#">see Remove leaks, page 51</a> ).				X*
Check heat exchanger for working fluid pressurising.				X
Check heat exchanger for corrosion. • Corrosion or damage on core tubes, fins, support structures, tube connections, fixtures: repair unit sections affected.				X*

\*) Recommended: every six months

### Care and maintenance plan

Measure	Cleaning agent	Interval
Remove frost and clean component	Mechanically	As required (visual inspection)
Heat exchanger defrosting	Circulation air, electric, ; automatic defrosting device; defrost locking device (flap, Shut-Up)	According to local conditions (penetrating moisture, air or chilled goods); with an ice thickness of 1 mm at the latest.
Complete cleaning	Warm water or environmentally safe cleaning agent	After 120 hours
Leak check		After 6 months
Corrosion protection check		After 6 months

## 10.3 Maintenance work

### 10.3.1 Remove leaks

#### ⚠ WARNING

Danger of injuries with ([see Residual hazards due to the heat carrier glycol, page 20](#))!

- Have leaks removed as quickly as possible by an expert.
  - Do not fill with a working fluid other than that specified in acc. with the order-related offer documents!
  - Only put the unit back into operation when all leaks have been repaired.
- ▶ Perform all work including pressure, acceptance and functional test ([see Perform acceptance test, page 41](#), and [see Test readiness for operation, page 42](#)).

## 10.4 Clean unit

### 10.4.1 General

The following applies for cleaning: The operator must ensure that the cleaning agents are environmental friendly and compatible for the materials in the system. Harmful to the environment substances, e.g. acid-forming, are forbidden.

#### ACHTUNG - ATTENTION - ATTENTION - ATENCIÓN

<p>Bei der Verwendung von Reinigungsmitteln in Kühlräumen, ist auf die Korrosionsbeständigkeit der Materialien des Kühlers gegenüber dem verwendeten Reinigungsmittel zu achten!</p>	<p>When cleaning agents are used inside the cold room, the corrosion resistance of the cooler materials to the applied cleaning agent has to be observed!</p>	<p>Lors de l'utilisation des détergents dans les chambres froides, il faut observer à la résistance à la corrosion des matériaux de l'appareil qui entrent en contact direct avec les détergents.</p>	<p>Cuando se apliquen agentes limpiadores en los productos instalados en cámaras frías, se debe tener cuidado que no corroen los materiales usados para la construcción del producto!</p>
--	---	---	---

- ▶ Clean casing by rinsing with warm water (approx. +25°C) and/or with environmentally friendly cleaning agents.
- ▶ Rinse thoroughly with water after using cleaning agents.
- ▶ Allow casing to dry completely.
- ▶ Check working fluid-side and electrical connections ([see Test readiness for operation, page 42](#)).

### 10.4.2 Clean and defrost heat exchanger

- ▶ Drain the unit (see system).
- ▶ Shut off the unit (see system).
- ▶ Power off the fans (see system).
- ▶ Clean the heat exchanger with one of the following procedures:

- Cleaning with compressed air (see [Cleaning with compressed air, page 52](#)).
- Hydraulic cleaning (see [Hydraulic cleaning, page 52](#)).

## NOTICE

Danger of damage to property!

The fins can be damaged with too high a pressure, too small a distance or a cleaning jet that hits the fins at an angle. Mechanical cleaning with hard objects (e.g. steel brushes, screw drivers, or similar) damages the heat exchanger.

- Use a pressure of max. 50 bar with hydraulic cleaning and max. 80 bar with cleaning with compressed air!
  - Maintain a minimum distance from the fins of 200 mm!
  - Always aim the jet vertically (max.  $\pm 5$  degree deviation) at the fins!
  - Do not use any hard objects when cleaning!
- ▶ Switch fans on (see system).
  - ▶ Open suction side (see system).
  - ▶ Open working fluid feed (see system).

### 10.4.2.1 Cleaning with compressed air

- ▶ Blast heat exchanger (max. 80 bar pressure) with compressed air to remove dirt and contaminants.

**NOTE! Hold the jet of the cleaner vertical to the fins (max. deviation of  $\pm 5$  degrees) to prevent fins from bending.**

### 10.4.2.2 Hydraulic cleaning

## ⚠ WARNING



Warns against dangerous electrical voltage!

Direct and indirect contact with voltage-carrying parts of motors and electrical lines can cause serious injuries or death. Water and cleaning agents conduct electricity.

- Power off the fans for cleaning with water or steam and where applicable the heater rods for electrical defrost and ensure them against switching on again.

## NOTICE

Danger of damage to property!

Water or steam jets can damage fans, electrical lines or other components.

- Ensure that electrical connections and motors, as well as components and stored goods at the set-up point are not touched by water or steam jets. Cover these if required.
- ▶ Heavier moisture or greasy dirt must be removed with a high-pressure water jet (max. 50 bar pressure), steam pressure jet (max. 50 bar pressure), min. 200 mm distance with flat jet nozzle, or using neutral cleaning agent where applicable, always against the airflow direction. Ensure here:

- With oily and greasy dirt it helps to add a cleaning agent to the water.
- When applying chemical agents ensure that they are not aggressive towards the unit's materials. Rinse the unit off after the treatment.
- Cleaning should be done from inside to the outside (but always opposing the dirt onset) and from top to bottom, so that the dirt can be removed without returning.
- Hold the jet of the cleaner vertical to the fins (heat exchanger – max. deviation of  $\pm 5$  degrees) to prevent fins from bending.

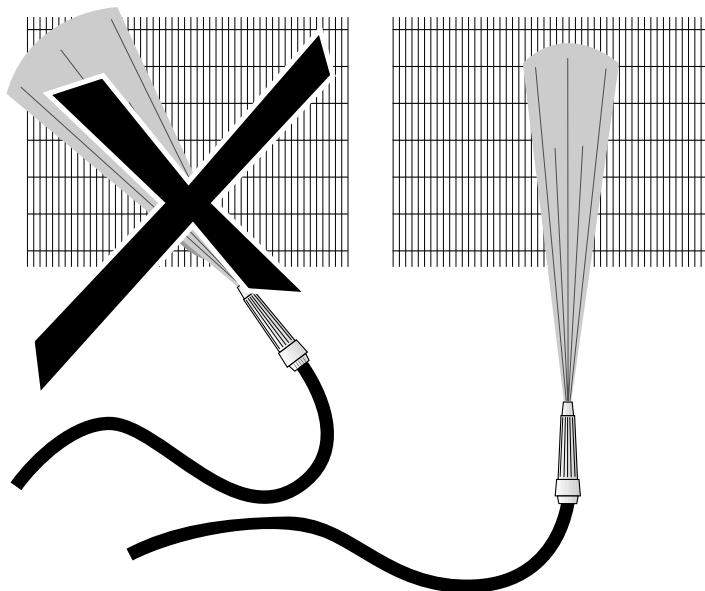

- ▶ Continue cleaning until all dirt has been removed.

### 10.4.3 Cleaning fans

#### WARNING

Danger of cutting off, pulling in!

There is a danger of cutting off fingers on the rotating fan blades, injury hazard for the hands and pulling in danger for loose elements such as hair, necklaces or clothing parts.

- Power off the unit before you begin maintenance work. Secure the unit against unintentional switching on again by removing the electric fuses for the unit. Secure the unit with a suitable warning sign referring to unintentional switching on.
- Put fans and guard grilles that were removed or opened for maintenance back into their original status without fail before you put the unit back into operation!

Dirt build-ups and frost and/or icing on the fans and the fan guard grilles must be removed regularly, otherwise they will cause imbalances or destruction and power losses. The fan motors themselves are maintenance-free.

- ▶ Power off the unit and secure it against unintentional switching on.
- ▶ Clean fans with one of the following procedures:

**NOTE! Danger of damage to property! Mechanical cleaning with hard objects (e.g. steel brushes, screw drivers, or similar) damages the fan. Forbidden!**

- Cleaning with compressed air: Blow fans with compressed air (max. 10 bar pressure; min. distance 200 mm) to remove dirt and contaminants. Continue cleaning until all dirt has been removed.
  - Cleaning with compressed air and brushes: Remove dry dust or dirt with a brush, a hand brush or with compressed air (max. 10 bar pressure, min. distance of 200 mm) or with a powerful industrial vacuum cleaner. Ensure here: use soft brushes (no steel brushes or similar)! Continue cleaning until all dirt has been removed.
- ▶ Mount guard grille
  - ▶ Switch unit on

## **11 Plans/diagrams**

### **11.1 Electrics documentation**

#### **11.1.1 Fan motor connection diagram**

---

See motor terminal box cover inside on the fan.

#### **11.1.2 Connection diagram electrical defrost (selectable option; accessory on customer request)**

---

See order-related offer documents